



3-Channel Constant-Current RGB LED Driver



FEATURES

- 3 independent current sinks rated to 25V
- LED current to 175mA per channel set by separate external resistors
- High-speed 25MHz 4-wire serial interface
- Buffered output drivers to ensure data integrity
- Cascadable devices
- Low dropout current source (0.4V at 175mA)
- 3V to 5.5V logic supply
- Thermal shutdown protection
- RoHS-compliant 16-lead SOIC package

APPLICATIONS

- Multi-color, intelligent LED, architectural lighting
- High-visual impact LED signs and displays
- LCD backlight

ORDERING INFORMATION

Part Number	Package	Quantity per Reel	Package Marking
CAT4103V-GT2	SOIC-16*	2,000	CAT4103V

* Lead Finish NiPdAu

DESCRIPTION

The CAT4103 is a 3-channel, linear based constant-current LED driver designed for RGB LED control, requiring no inductor and provides a low noise operation. LED channel currents up to 175mA are programmed independently via separate external resistors. Low output voltage operation of 0.4V at 175mA allows for more power efficient designs across wider supply voltage range. The three LED pins are compatible with high voltage up to 25V supporting applications with long strings of LEDs.

A high-speed 4-wire 25MHz serial interface controls each individual channel using a shift register and latch configuration. Output data pins allow multiple devices to be cascaded and programmed via one serial interface with no need for external drivers or timing considerations. The device also includes a blanking control pin (BIN) that can be used to disable all channels independently of the interface.

Thermal shutdown protection is incorporated in the device to disable the LED outputs whenever the die temperature exceeds 150°C.

The device is available in a 16-lead SOIC package.

PIN CONFIGURATION

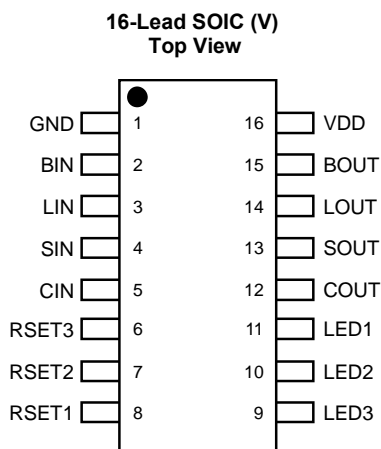

TYPICAL APPLICATION CIRCUIT

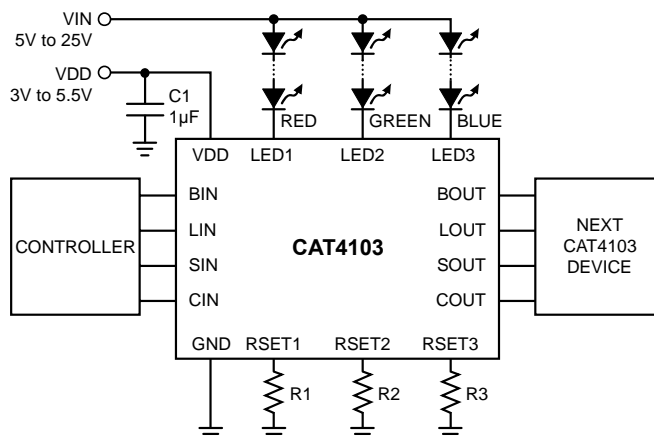

ABSOLUTE MAXIMUM RATINGS

Parameter	Rating	Units
VDD Voltage	6	V
Input Voltage Range (SIN, BIN, CIN, LIN)	-0.3V to VDD+0.3V	V
Output voltage range (SOUT, BOUT, COUT, LOUT)	-0.3V to VDD+0.3V	V
LED1, LED2, LED3 Voltage	25	V
DC Output Current on LED1 to LED3	200	mA
Storage Temperature Range	-55 to +160	°C
Junction Temperature Range	-40 to +150	°C
Lead Soldering Temperature (10sec.)	300	°C
ESD Rating: All Pins Human Body Model Machine Model	2000 200	V

RECOMMENDED OPERATING CONDITIONS

Parameter	Range	Units
VDD	3.0 to 5.5	V
Voltage applied to LED1 to LED3, outputs off	up to 25	V
Voltage applied to LED1 to LED3, outputs on	up to 6*	V
Output Current on LED1 to LED3	2 to 175	mA
Ambient Temperature Range	-40 to +85	°C

* Keeping the LEDx pin voltage below 6V in operation is recommended to minimize thermal dissipation in the package.

ELECTRICAL OPERATING CHARACTERISTICS

DC CHARACTERISTICS

Min and Max values are over recommended operating conditions unless specified otherwise.

Typical values are at $V_{IN} = 5.0V$, $T_{AMB} = 25^{\circ}C$

Symbol	Name	Conditions	Min	Typ	Max	Units
I_{DD1}	Supply Current Outputs Off	$V_{LED} = 5V$, $R_{SET} = 24.9k\Omega$		2	5	mA
I_{DD2}	Supply Current Outputs Off	$V_{LED} = 5V$, $R_{SET} = 5.23k\Omega$		4	10	mA
I_{DD3}	Supply Current Outputs On	$V_{LED} = 0.5V$, $R_{SET} = 24.9k\Omega$		2	5	mA
I_{DD4}	Supply Current Outputs On	$V_{LED} = 0.5V$, $R_{SET} = 5.23k\Omega$		4	10	mA
I_{LKG}	LED Output Leakage	$V_{LED} = 5V$, Outputs Off	-1		1	μA
R_{LIN}	LIN Pull-down Resistance		140	180	250	k Ω
R_{BIN}	BIN Pull-up Resistance		140	180	250	k Ω
V_{IH} V_{IL}	SIN, BIN, CIN, LIN logic high level SIN, BIN, CIN, LIN logic low level		$0.7x V_{DD}$		$0.3x V_{DD}$	V
I_{IL}	Logic Input Leakage Current (CIN, SIN)	$V_i = V_{DD}$ or GND	-5	0	5	μA
V_{OH} V_{OL}	xOUT Logic High Output Voltage xOUT Logic Low Output Voltage	$I_{OH} = -1mA$ $I_{OL} = 1mA$	$V_{CC}-0.3V$		0.3	V
V_{RSET}	RSETx Regulated Voltage		1.17	1.2	1.23	V
T_{SD}	Thermal Shutdown			150		°C
T_{HYS}	Thermal Hysteresis			20		°C
I_{LED}/I_{RSET}	RSET to LED Current Gain ratio	100mA LED Current		400		
V_{UVLO}	Undervoltage Lockout (UVLO) Threshold			1.8		V

TIMING CHARACTERISTICS

Min and Max values are over recommended operating conditions unless specified otherwise.

Typical values are at $V_{IN} = 5.0V$, $T_{AMB} = 25^{\circ}C$

Symbol	Name	Conditions	Min	Typ	Max	Units
CIN						
f_{cin}	CIN Clock Frequency				25	MHz
t_{cwh}	CIN Pulse Width High		18			ns
t_{cwl}	CIN Pulse Width Low		18			ns
SIN						
t_{ssu}	Setup time SIN to CIN		4			ns
t_{sh}	Hold time SIN to CIN		4			ns
LIN						
T_{lwh}	LIN Pulse width		20			ns
t_{lchd}	Hold time LIN to CIN		4			ns
t_{lcsu}	Setup time LIN to CIN		8			ns
LEDn						
$t_{ledplon}$	Turn on Propagation delay LIN	LIN to LED(n) on		380		ns
$t_{ledploff}$	Turn off Propagation delay LIN	LIN to LED(n) off		130		ns
$t_{ledpbon}$	Turn on Propagation delay BIN	BIN to LED(n) on		380		ns
$t_{ledpboff}$	Turn off Propagation delay BIN	BIN to LED(n) off		130		ns
t_{ledr}	LED rise time (10% to 90%)	Pullup resistor = 50 Ω to 3.0V		160		ns
t_{ledf}	LED fall time (90% to 10%)	Pullup resistor = 50 Ω to 3.0V		140		ns
SOUT						
t_{sr}	SOUT rise time (10% to 90%)	$C_L = 15pF$		5		ns
t_{sf}	SOUT fall time (90% to 10%)	$C_L = 15pF$		5		ns
t_{sdf}	Propagation delay time SOUT	CIN falling to SOUT falling		6	18	ns
t_{sdr}	Propagation delay time SOUT	CIN falling to SOUT rising		6	18	ns
COUT						
t_{cr}	COUT rise time (10% to 90%)	$C_L = 15pF$		5		ns
t_{cf}	COUT fall time (90% to 10%)	$C_L = 15pF$		5		ns
t_{cdf}	Propagation delay time COUT	CIN falling to COUT falling		4	10	ns
t_{cdr}	Propagation delay time COUT	CIN rising to COUT rising		4	10	ns
LOUT						
t_{lr}	LOUT rise time (10% to 90%)	$C_L = 15pF$		5		ns
t_{lf}	LOUT fall time (90% to 10%)	$C_L = 15pF$		5		ns
t_{ldf}	Propagation delay time LOUT	LIN falling to LOUT falling		4	10	ns
t_{ldr}	Propagation delay time LOUT	LIN rising to LOUT rising		5	10	ns
BOUT						
t_{br}	BOUT rise time (10% to 90%)	$C_L = 15pF$		5		ns
t_{bf}	BOUT fall time (90% to 10%)	$C_L = 15pF$		5		ns
t_{bdf}	Propagation delay time BOUT	BIN falling to BOUT falling		6	20	ns
t_{bdr}	Propagation delay time BOUT	BIN rising to BOUT rising		8	20	ns

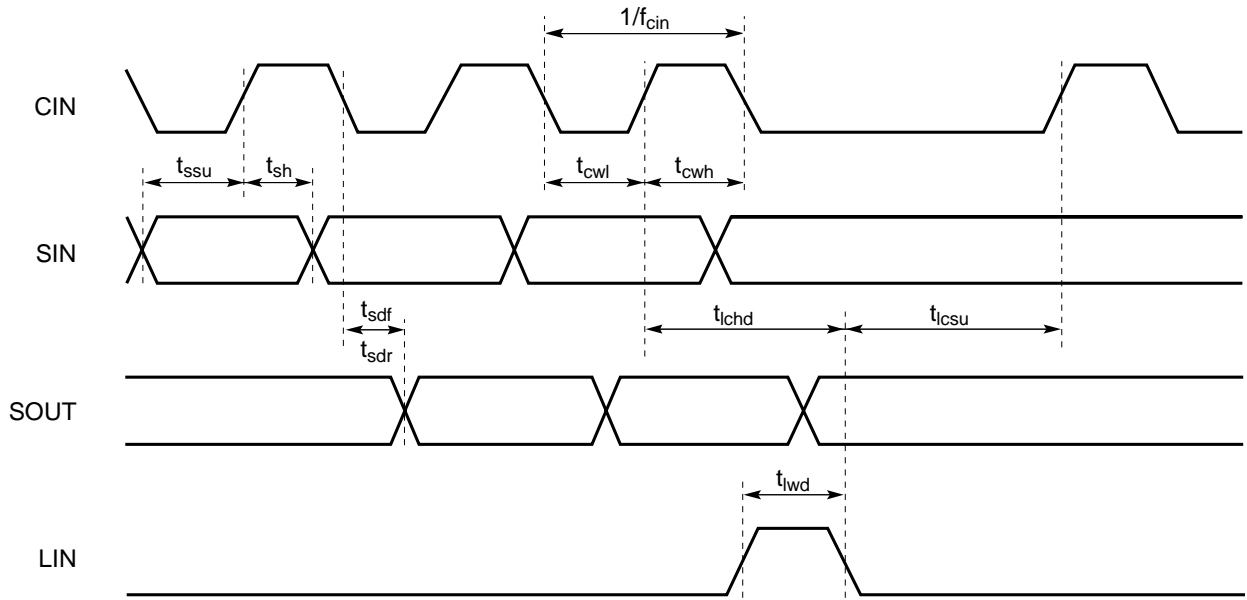

Figure 2. Timing Diagram A

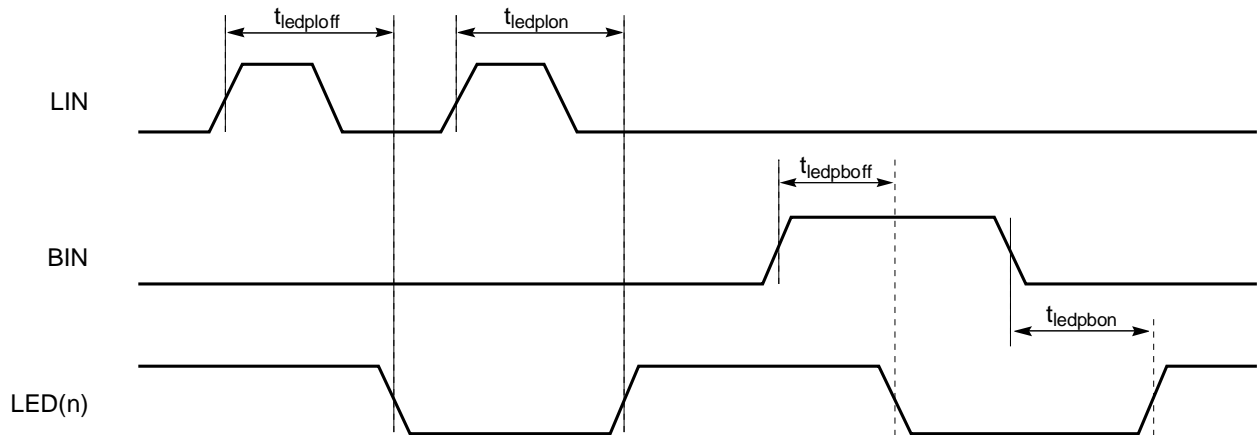
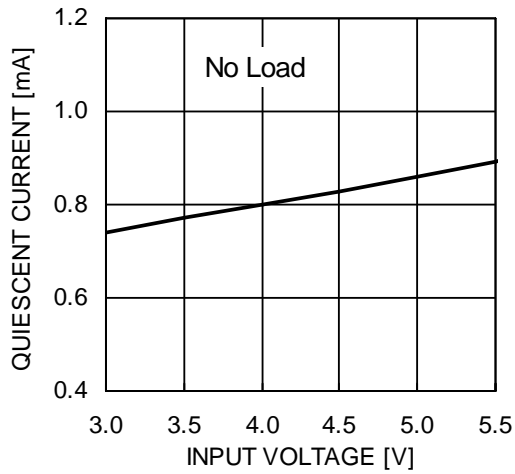

Figure 3. Timing Diagram B

TYPICAL PERFORMANCE CHARACTERISTICS

$V_{IN} = 5V$, $V_{DD} = 5V$, $C1 = 1\mu F$, $T_{AMB} = 25^{\circ}C$ unless otherwise specified.

Quiescent Current vs. Input Voltage ($I_{LED} = 0mA$)



Quiescent Current vs. RSET Current

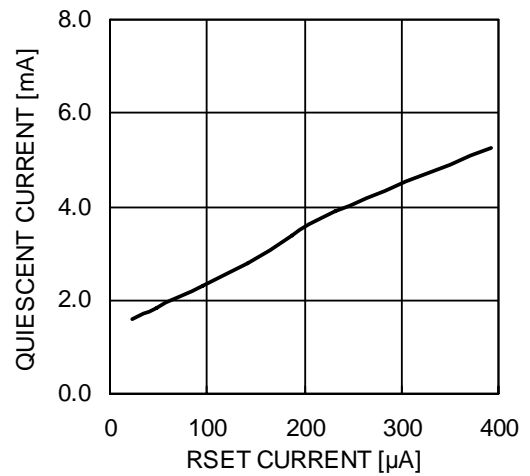

Quiescent Current vs. Input Voltage ($I_{LED} = 175mA$)

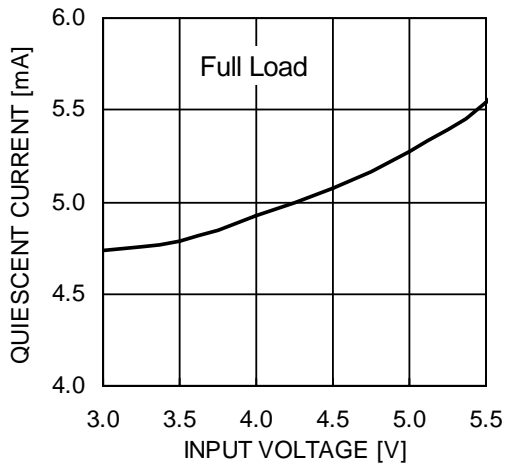

LED Current vs. LED Pin Voltage

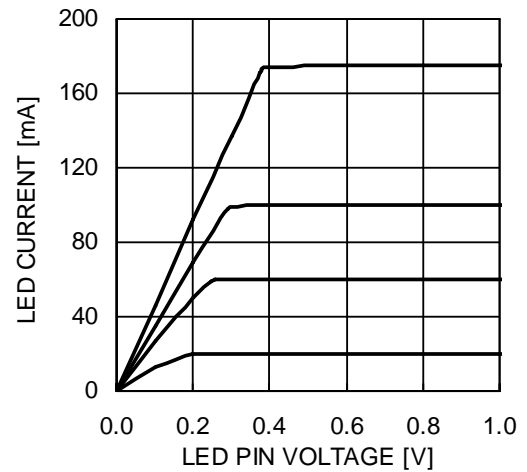

LED Current Change vs. Input Voltage

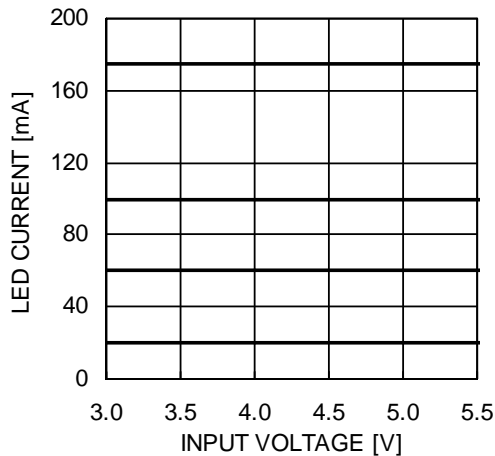

LED Current Change vs. Temperature

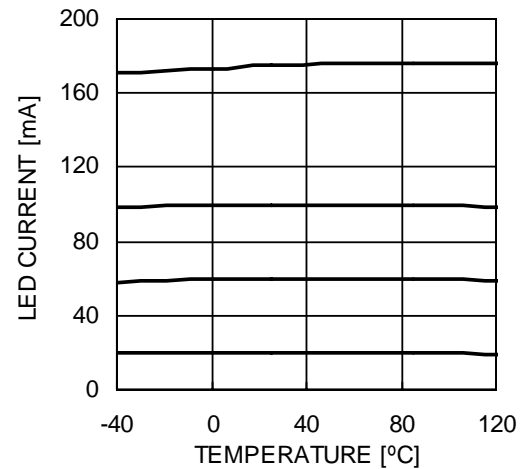

TYPICAL PERFORMANCE CHARACTERISTICS

$V_{IN} = 5V$, $V_{DD} = 5V$, $C_1 = 1\mu F$, $T_{AMB} = 25^\circ C$ unless otherwise specified.

RSET Pin Voltage vs. Input Voltage

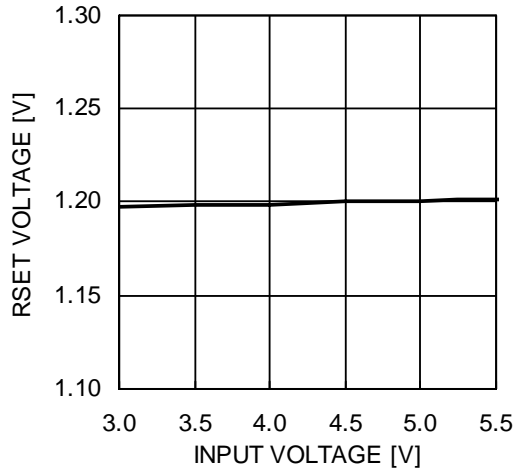

RSET Pin Voltage vs. Temperature

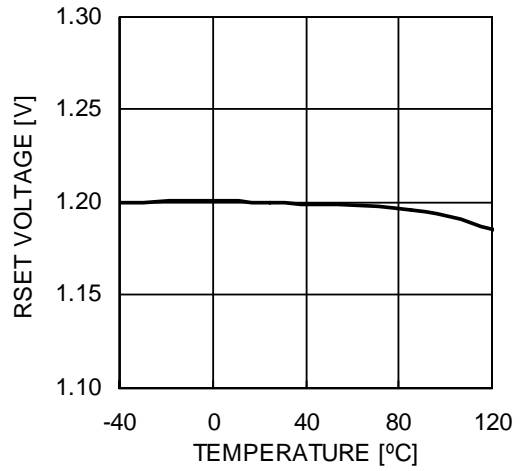

LED Current vs. RSET Resistor

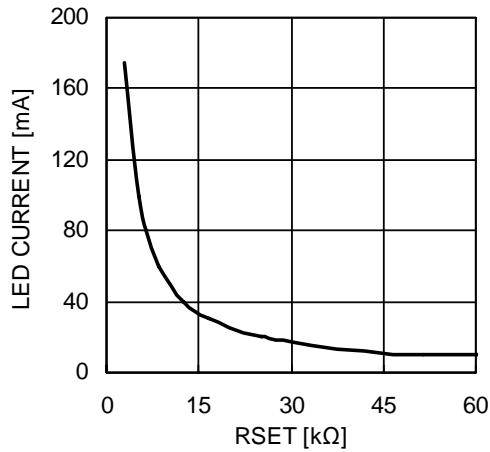

BIN Transient Response

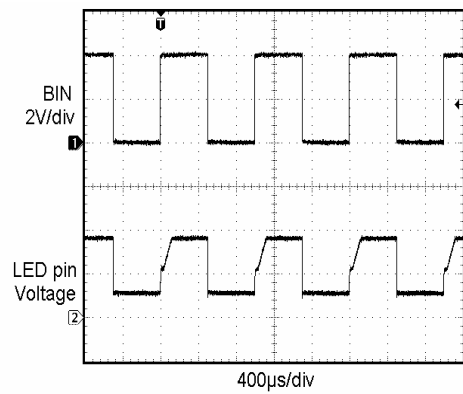

PIN DESCRIPTIONS

Name	Pin Number	Function
GND	1	Ground Reference
BIN	2	Blank input pin
LIN	3	Latch Data input pin
SIN	4	Serial Data input pin
CIN	5	Serial Clock input pin
RSET3	6	LED current set pin for LED3
RSET2	7	LED current set pin for LED2
RSET1	8	LED current set pin for LED1
LED3	9	LED channel 3 cathode terminal
LED2	10	LED channel 2 cathode terminal
LED1	11	LED channel 1 cathode terminal
COUT	12	Serial Clock output pin
SOUT	13	Serial Data output pin
LOUT	14	Latch Data output pin
BOUT	15	Blank output pin
VDD	16	Device Supply pin

PIN FUNCTION

GND is the ground reference pin for the entire device. This pin must be connected to the ground plane on the PCB.

BIN is the blank input used to disable all channels. When low, all LED channels are enabled according to the output latch content. When high, all LED channels are turned off. This pin can be used to turn all the LEDs off while preserving the data in the output latches.

LIN is the latch data input. On the rising edge of LIN, data is loaded from the 3-bit serial shift register into the output register latch. On the falling edge of LIN the data is latched in the output register and isolated from the state of the serial shift register.

SIN is the serial data input. Data is loaded into the internal register on each rising edge of CIN.

CIN is the serial clock input. On each rising CIN edge, data is transferred from SIN to the internal 3-bit serial shift register.

RSET1 to RSET3 are the LED current set inputs. The current pulled out of these pins will be mirrored in the corresponding LED channel with a gain of 400.

LED1 to LED3 are the LED current sink inputs. These pins are connected to the bottom cathodes of the LED strings. The current sinks bias the LEDs with a current equal to 400 times the RSET pin current. For the LED sink to operate correctly, the voltage on the LED pin must be above 0.4V. Each LED channel can withstand and operate with voltages up to 25V.

COUT is a driven output of CIN and can be connected to the next device in the cascade.

SOUT is the output of the 3-bit serial shift register. Connect to SIN of the next device in the cascade. SOUT is clocked on the falling edge of CIN.

LOUT is a driven output of LIN and can be connected to the next chip in the cascade.

BOUT is a driven output of BIN and can be connected to the next chip in the cascade.

VDD is the positive supply pin voltage for the entire device. A small 1 μ F ceramic capacitor is recommended close to the pin.

BLOCK DIAGRAM

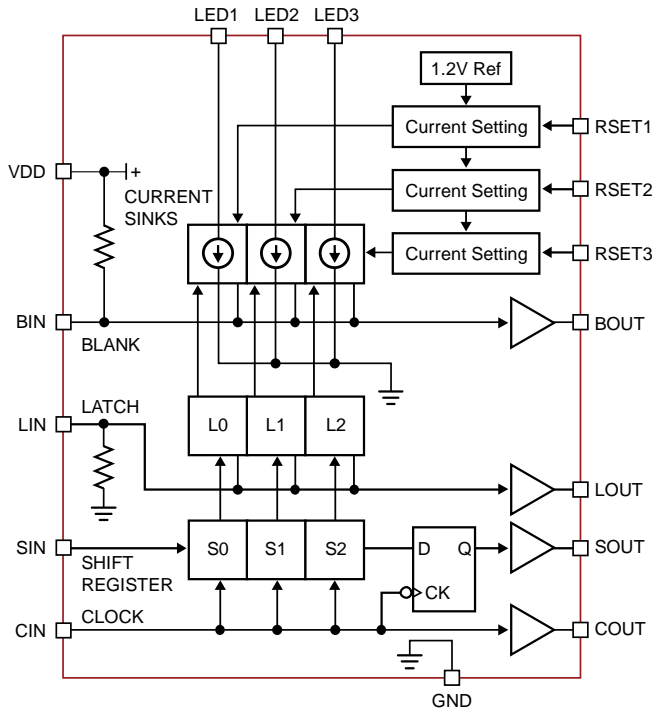

Figure 1. CAT4103 Functional Block Diagram

BASIC OPERATION

The CAT4103 uses 3 independent current sinks to accurately regulate the current in each LED channel to 400 times the current sink from the corresponding RSET pin. Each of the resistors tied to the RSET1, RSET2, RSET3 pins set the current respectively in the LED1, LED2, and LED3 channels. Table 1 shows some standard resistor values for RSET and the corresponding LED current.

Table 1. RSET Resistor Settings

LED Current [mA]	RSET[kΩ]
20	24.9
60	8.45
100	5.23
175	3.01

Tight current regulation for all channels is possible over a wide range of input and LED voltages due to independent current sensing circuitry on each channel. The LED channels have a low dropout of 0.4V or less for all current ranges and supply voltages. This helps improve heat dissipation and efficiency over other competing solutions.

Upon power-up, an under-voltage lockout circuit clears all latches and shift registers and sets all outputs to off. Once the VDD supply voltage is greater than the under-voltage lockout threshold, the device can be programmed.

Pull-up and pull-down resistors are internally provided to set the state of the BIN and LIN pins to low current off state when not externally driven.

A high-speed 4-wire interface is provided to program the state of each LED channel ON or OFF.

The 4-wire interface contains a 3-bit serial-to-parallel shift register (S0-S2) and a 3-bit latch (L0-L2). The shift register operates on a first-in first-out (FIFO) basis. The most significant bit S2 corresponds to the first data entered in from SIN. Programming the serial-to-parallel register is accomplished via SIN and CIN input pins. On each rising edge of the CIN signal the data from SIN is moved through the shift register serially. Data is also moved out of SOUT to the next device if programming more than one device on the same interface.

On the rising edge of LIN, the data content of the serial to parallel shift register is reflected in the latches. On the falling edge of LIN, the state of the serial-to-parallel register at that particular time is saved in the latches and does not change regardless of the content of the serial to parallel register.

BIN is used to disable all LEDs off at one time while still maintaining the data contents of the latch register. BIN is an active low input pin. When low the outputs reflect the data in the latches. When high the outputs are all high impedance (LEDs off).

All 4-wire inputs have a corresponding output driver for cascaded systems (SOUT, COUT, LOU, BOUT). These output buffers allow many CAT4103 drivers to be cascaded without signal and timing degradation due to long wire interconnections.

APPLICATION INFORMATION

CASCADING MULTIPLE DEVICES

The CAT4103 is designed to be cascaded for driving multiple RGD LEDs. Figure 5 shows three CAT4103 drivers cascaded together. The programming data from the controller travels serially through each device. Figure 4 shows a programming example turning on the following LED channels: BLUE3, GREEN2 and RED1. The programming waveforms are measured from the controller to the inputs of the first CAT4103.

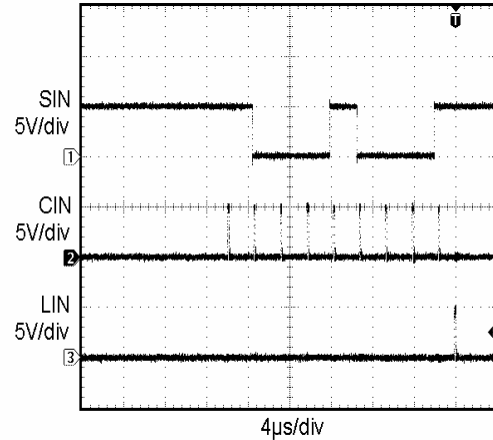

Figure 4. Programming Example

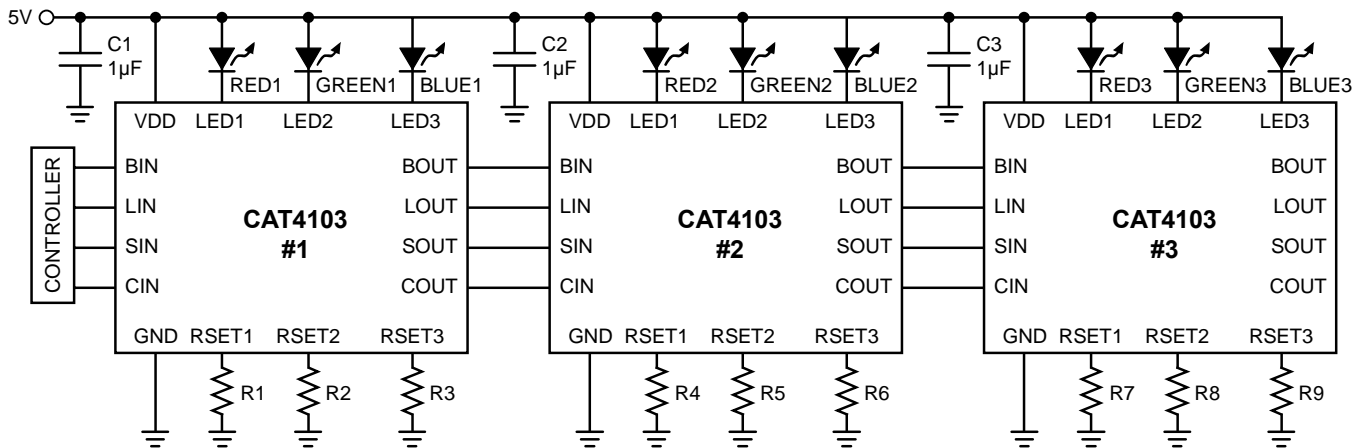

Figure 5. Three Cascaded CAT4103 Devices

POWER DISSIPATION

The power dissipation (P_D) of the CAT4103 can be calculated as follows:

$$P_D = (V_{DD} \times I_{DD}) + \sum(V_{LEDN} \times I_{LEDN})$$

where V_{LEDN} is the voltage at the LED pin, and I_{LEDN} is the associated LED current. Combinations of high V_{LED} voltage or high ambient temperature can cause the CAT4103 to enter thermal shutdown. In applications where V_{LEDN} is high, a resistor can be inserted in series with the LED string to lower P_D .

Thermal dissipation of the junction heat consists primarily of two paths in series. The first path is the junction to the case (θ_{JC}) thermal resistance which is defined by the package style, and the second path is the case to ambient (θ_{CA}) thermal resistance, which is dependent on board layout. The overall junction to ambient (θ_{JA}) thermal resistance is equal to:

$$\theta_{JA} = \theta_{JC} + \theta_{CA}$$

For a given package style and board layout, the operating junction temperature T_J is a function of the power dissipation P_D , and the ambient temperature, resulting in the following equation:

$$T_J = T_{AMB} + P_D (\theta_{JC} + \theta_{CA}) = T_{AMB} + P_D \theta_{JA}$$

When mounted on a double-sided printed circuit board with two square inches of copper allocated for "heat spreading", the resulting θ_{JA} is about 74°C/W.

For example, at 60°C ambient temperature, the maximum power dissipation is calculated as follow:

$$P_{Dmax} = \frac{(T_{Jmax} - T_{AMB})}{\theta_{JA}} = \frac{(150 - 60)}{74} = 1.2W$$

RECOMMENDED LAYOUT

Bypass capacitor C1 should be placed as close to the IC as possible. RSET resistors should be directly connected to the GND pin of the device. For better thermal dissipation, multiple via can be used to connect the GND pad to a large ground plane. It is also recommended to use large pads and traces on the PCB wherever possible to spread out the heat. The LEDs for this layout are driven from a separate supply (VLED+), but they can also be driven from the same supply connected to VDD.

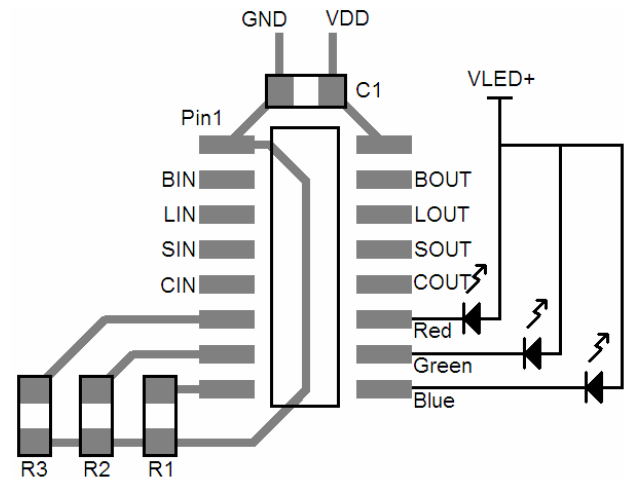
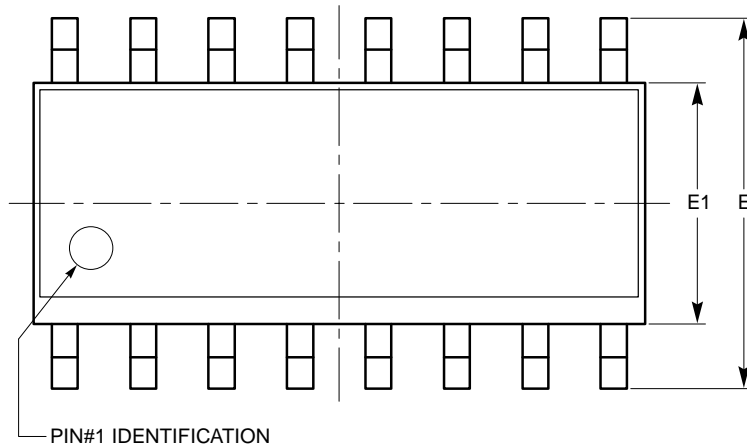

Figure 6. Recommended Layout

PACKAGE OUTLINE DRAWING

SOIC 16-LEAD 150MILS (V) ⁽¹⁾⁽²⁾



TOP VIEW

SYMBOL	MIN	NOM	MAX
A	1.35		1.75
A1	0.10		0.25
b	0.33		0.51
c	0.19		0.25
D	9.80	9.90	10.00
E	5.80	6.00	6.20
E1	3.80	3.90	4.00
e	1.27 BSC		
h	0.25		0.50
L	0.40		1.27
θ	0°		8°

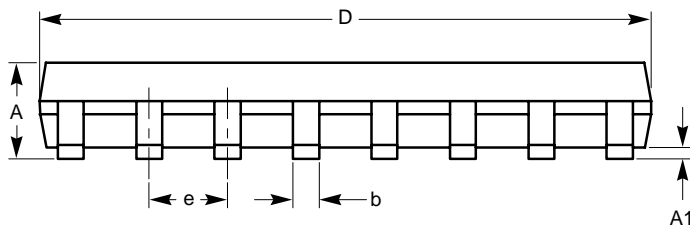

SIDE VIEW

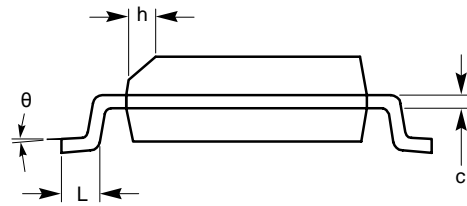

END VIEW

Notes:

- (1) All dimensions in millimeters. Angle in degrees.
- (2) Compiles with JEDEC standard-012.

EXAMPLE OF ORDERING INFORMATION

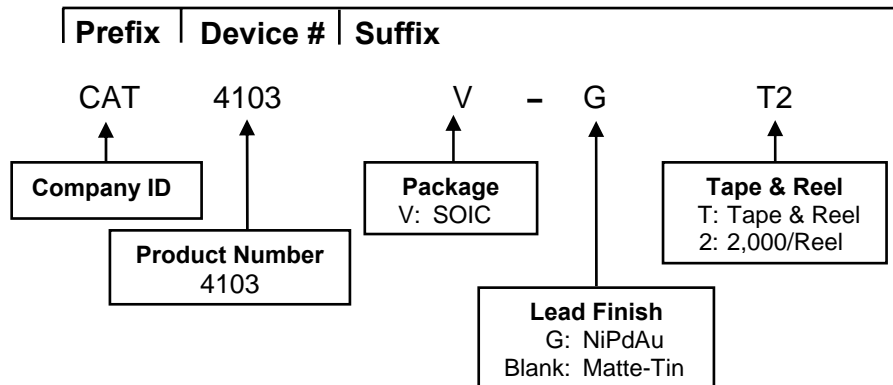

Notes:

- (1) All packages are RoHS-compliant (Lead-free, Halogen-free).
- (2) The standard plated finish is NiPdAu.
- (3) The device used in the above example is a CAT4103V-GT2 (SOIC, NiPdAu, Tape & Reel, 2,000/Reel).
- (4) For additional temperature options, please contact your nearest ON Semiconductor Sales office.

REVISION HISTORY

Date	Revision	Description
31-Oct-08	A	Initial Issue
23-Jul-09	B	Update Electrical Operating Characteristics - DC Characteristics

ON Semiconductor and  are registered trademarks of Semiconductor Components Industries, LLC (SCILLC). SCILLC reserves the right to make changes without further notice to any products herein. SCILLC makes no warranty, representation or guarantee regarding the suitability of its products for any particular purpose, nor does SCILLC assume any liability arising out of the application or use of any product or circuit, and specifically disclaims any and all liability, including without limitation special, consequential or incidental damages. "Typical" parameters which may be provided in SCILLC data sheets and/or specifications can and do vary in different applications and actual performance may vary over time. All operating parameters, including "Typicals" must be validated for each customer application by customer's technical experts. SCILLC does not convey any license under its patent rights nor the rights of others. SCILLC products are not designed, intended, or authorized for use as components in systems intended for surgical implant into the body, or other applications intended to support or sustain life, or for any other application in which the failure of the SCILLC product could create a situation where personal injury or death may occur. Should Buyer purchase or use SCILLC products for any such unintended or unauthorized application, Buyer shall indemnify and hold SCILLC and its officers, employees, subsidiaries, affiliates, and distributors harmless against all claims, costs, damages, and expenses, and reasonable attorney fees arising out of, directly or indirectly, any claim of personal injury or death associated with such unintended or unauthorized use, even if such claim alleges that SCILLC was negligent regarding the design or manufacture of the part. SCILLC is an Equal Opportunity/Affirmative Action Employer. This literature is subject to all applicable copyright laws and is not for resale in any manner.

PUBLICATION ORDERING INFORMATION

LITERATURE FULFILLMENT:

Literature Distribution Center for ON Semiconductor
P.O. Box 5163, Denver, Colorado 80217 USA
Phone: 303-675-2175 or 800-344-3860 Toll Free USA/Canada
Fax: 303-675-2176 or 800-344-3867 Toll Free USA/Canada
Email: orderlit@onsemi.com

N. American Technical Support: 800-282-9855 Toll Free
USA/Canada

Europe, Middle East and Africa Technical Support:
Phone: 421 33 790 2910

Japan Customer Focus Center:
Phone: 81-3-5773-3850

ON Semiconductor Website: www.onsemi.com

Order Literature: <http://www.onsemi.com/orderlit>

For additional information, please contact your local Sales Representative